



National BIM Report

for Manufacturers 2016



Introduction 03

Ian Chapman
Director of National BIM Library, NBS

BIM and the digital revolution 06

Anthony Harte
Director at James & WARD Ltd

Origins3 Studio and our transition to BIM 08

Russ Green
Architect at Origin3 Studio

Presenting product information fit for BIM 12

Drew Wiggett
Head of Product Information, NBS

Meeting the mandate – the Mott MacDonald story 16

Andrew Moulds
Associate at Mott MacDonald

BIM Survey: The findings 22

Adrian Malleson
Head of Research, Analysis and Forecasting, NBS

BIM and the manufacturer 30

Contributors:
Vicky Evans,
Managing Director, Twinfix
Andy Duck,
Marketing and Communications Manager,
Bruynzeel Storage Systems
Edward Rose,
BIM Project Leader, Ecoprod
Lee Jones,
BIM Manager, Ideal Standard

The impact of BIM on product selection throughout the project timeline 38

David Bain
Research Manager, NBS

RIBA Enterprises Ltd © 2016 All rights reserved. No part of this report may be reproduced or shared in any form or by any means, electronic or mechanical, including photocopying, recording, or by any information storage or retrieval system, without permission in writing from the copyright holder.

The content of articles contributed by external authors and published in this report are the views of those authors and do not represent the position of RIBA Enterprises Ltd, NBS or its affiliated companies.



Introduction



Ian Chapman
Director of National BIM Library, NBS



Change is constant. Over the past five years, the construction sector has embarked on a period of rapid change as it transforms into a truly digital industry.

The UK Government BIM mandate has driven this change, supported by the creation of standards, guides and tools (bim-level2.org). However, with change comes a series of stages that businesses experience. The first stage is often denial, closely followed by resistance, then acceptance where opportunities are explored. The final phase is commitment and adoption – where the benefits of change can be realised. When it comes to BIM, what stage are construction product manufacturers at? Where would you place your business?

From April 4th this year, all centrally procured projects need to achieve BIM Level 2. But BIM Level 2 is just a starting point on the journey of digitisation.

Over the past few years many manufacturers have been in denial about the changes BIM will bring. Denial fades in the face of an increasingly collaborative industry in which shared, standardised information is the backbone of a digitised, BIM practicing, sector. There is a wealth of information on BIM; the early adopters have already answered many questions. Learn from their experience and understand the pitfalls and benefits.

Resistance to change is a natural reaction, but it is important to consider the reasons behind this. Is the resistance due to a lack of awareness of the need to change or a lack of knowledge?

Resistance to change can be costly, allowing more agile challengers time to enter your market. Businesses that stick with the status quo have a risky future. Combat resistance through assessing the case for change. Create a BIM strategy that includes clear timescales and defines why BIM is important to your business. Communication throughout your organisation will help your business move to the options and adoption stages. If a business becomes stuck in the resistance phase, its long-term success is threatened.

When it comes to BIM, there are many options for construction product manufacturers to explore. Firstly look at your own product data. Most manufacturers already have product data in an electronic form; this is a big step, already taken, towards becoming BIM ready. For BIM Level 2 that information needs to be held in a structured format. By providing your product information in a 'product data sheet' you make your data significantly more attractive to those working with BIM. By placing your product information into a product data sheet you give your existing data a new lease of life. This structured information offers designers and contractors an easier, more transparent means of product discovery, allowing product comparison and selection. Creating product data sheets is easy – you already have the product knowledge and the product data, so combine this with one of the 5,000 product data templates available through the NBS BIM Toolkit and you have a product data sheet.

We would like to thank the following organisations for supporting this report:



Designers spend a lot of time drawing and specifying, so consider options that can help you to embed your product data into their workflows. BIM objects provide manufacturers with the opportunity for your product(s) to be used as part of the building design. A BIM object is a combination of your product geometry and product data, and the demand for BIM objects is high; 71% of survey respondents need manufacturers to provide them.

Since the launch of the freely available NBS BIM Object Standard in September 2014, it has become an invaluable tool to help manufacturers create BIM objects that are suitable for today's market. Anyone considering creating BIM objects themselves will find the online version with its extensive guidance indispensable. Not all products are contained within the project design model, so explore options that place your product data into specification systems such as NBS too.

Consider the options that are the most appropriate for your business. Whichever option you choose, make sure you get the most out of your digital product information. Don't hide it away, make sure it is easily found, and keep it up to date. This will be the foundation of successful BIM adoption in your business and a significant step towards seeing BIM deliver clear results for your business.

When it comes to BIM the direction of travel is clear. BIM is becoming the norm for design, construction and maintenance. With the early success of centrally funded projects, real savings are evident. Change is the one thing you can count on and that's a good thing. So don't get stuck by change, use it for competitive advantage.

Since the launch of the freely available NBS BIM Object Standard in September 2014, it has become an invaluable tool to help manufacturers create BIM objects that are suitable for today's market.



NBS BIM Object Standard

Quality assurance and consistency for all BIM objects

BIM objects that meet the NBS BIM Object Standard are consistent, accurate and compatible with the industry-leading specification and design software tools. The standard gives a reassurance of high quality and enables greater collaboration and a more efficient information exchange across the construction industry.

All BIM objects **authored by NBS meet the Standard**. We also offer a **certification and hosting service** for manufacturers who create their own BIM objects.

Find out more about creating or hosting your BIM objects on **0345 200 1056**

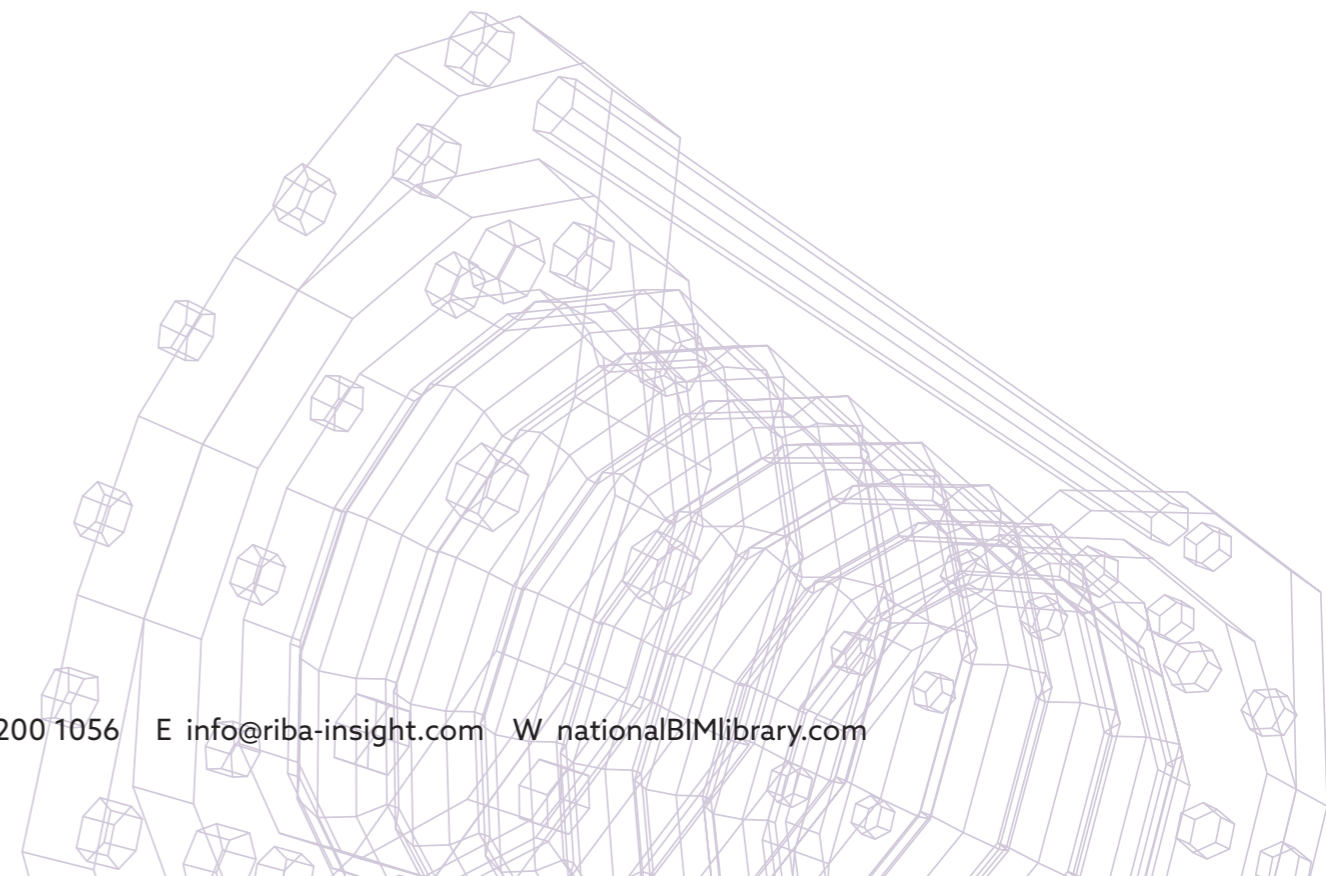
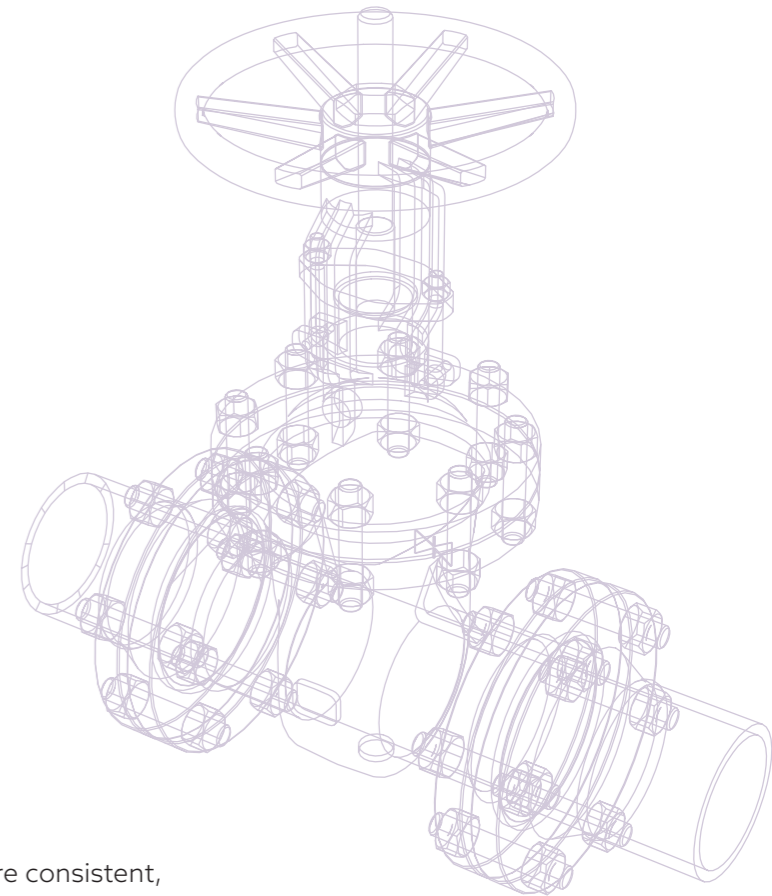

T 0345 200 1056 E info@riba-insight.com W nationalBIMlibrary.com

BIM and the digital revolution



Anthony Harte
Director at James
& WARD Ltd

Statistically, it is more than likely that you are reading this article in a digital form, whether online or in a downloaded PDF. You may have found the article via Twitter, a newsletter or a blog referring to it as a source of information. We can be sure that the digital revolution is truly upon us and that the construction industry is still playing catch-up in this area.

"...the digital revolution is truly upon us and the construction industry is still playing catch-up..."

It's fair to say that the TV and retail industries had a good head start in the digital age, with some of the biggest retailers collecting digital customer data for many years. Most sectors are now starting to take advantage of this digital era, and are using it to target marketing campaigns and promotions at the right time to the right people. But digital data within the retail sector only spreads as far as customer profiling, such as loyalty cards and online shopping habits. What about the construction and operational side of the buildings in which these businesses reside?

That's where BIM comes in: the magical and mystical acronym which has caused such a stir in the last few years, particularly in the run-up to the Government's April 2016 mandate. Whichever way you look at it, BIM is making itself known within the construction sector and has a lot in common with the Digital TV revolution. When HDTV first came about, many of us spent hours scratching our heads with questions such as: 'Do we need HD Ready, HD 720, HD 1080p, HD 4k?' And undoubtedly as end-users/customers, we initially had to pay a premium at the time for a better product and to be ahead of the game.

There are similar questions in the construction industry such as: 'Do we need to be BIM Ready, BIM L2, BIM L3, BIM 6D, BIM LOD8?' (Okay, so I made some of these up, but people often get these confused!).

In 2005, a licence agreement was introduced by Digital Europe who developed four labels or logos accrediting various features for Digital TVs. This agreement gives minimum requirements, testing and verification details, logo usage guidelines etc. and these still govern the terms under which you can use HD TV logos today. So what about the construction sector?



Far Left: The HD TV guideline compliance logo

Left: An example of a possible compliance logo for BIM

"Who can we turn to for a compliance check...?"

Before we can standardise and demonstrate compliance in the 'BIM world', we first need to have concise documentation that lists the standards required to meet the various 'Levels'. Now some might argue that we do already have (or are close to having) these, but there are still many discrepancies and disagreements. Who can we turn to for a compliance check when the industry is still in dispute about what Level 2 means, never mind identifying which standards are compliant, due to the various discrepancies between documents? It's great to see the standards being developed and updated, as most of the documents available today didn't exist when we started our BIM Journey at James & WARD back in 2008.

"The NBS National BIM Library and NBS BIM Object Standard are a win-win for architects, manufacturers and the client..."

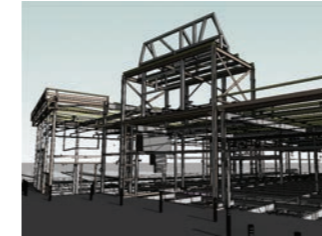

A federated model was used for Asda Barnes Hill to aid value engineering, collaborative working and clash detection, generating a £1.7m saving.

See more at: jamesward.org.uk

When I first started working in BIM, one of the first complex objects/assets I had to build virtually was a KONE TM115 traveller for a retailer. At the time I told my boss (now co-director) that it only took me 'a couple of hours'. It did in fact take me a whole day, but if the manufacturer had provided their content in a BIM-ready format, not only would I have saved my company a day's work, but I could also have better spent that time elsewhere - actually designing, for instance! So as a result, the cost of having to produce this information is ultimately passed on to the client.

By working together with manufacturers and following the NBS BIM Object Standard, we only need to create objects once. This increases accuracy at every stage of the build and achieves substantial savings in terms of lifecycle costs, not to mention allowing the designers to do what they do best, and helping manufacturers sell more products. What's not to like?

Structured data has a massive role in BIM, and by following set standards we are establishing the foundations for managing this data now and in the future. The NBS BIM Object Standard and the NBS National BIM Library host manufacturers' information to agreed set standards with suitable levels of useful data and information attached.

Summary

To summarise, the industry needs structured, approved, trusted content and useful data to start laying the foundations for our future generations. It's thanks to NBS with their investment in the NBS BIM Object Standard, the NBS National BIM Library, integrated specification tools and the NBS BIM Toolkit that the industry is finally starting to achieve this. The future will see building operators harvesting the facilities management and lifecycle data from our operational buildings. This in turn will provide real-time feedback from our built assets, enabling predictive decisions and giving us a greater understanding of the performance we can expect from our virtual models. It's important that we remember how the data we capture today influences the specification of tomorrow.

"Harvesting FM data and real time feedback will reduce lifecycle costs."

That future is now.

Whichever way you look at it, BIM is making itself known within the construction sector and has a lot in common with the Digital TV revolution.

Origins3 Studio and our transition to BIM



Russ Green
Architect at
Origin3 Studio

ORIGIN3 STUDIO

Origin3 Studio is a relatively new practice formed in 2011. The 'BIM transition' was easier for us than most as we didn't have to concern ourselves with gradual transitions. The direction of travel towards BIM was quite clear, and it was also clear what the most used software platform would be, so we invested in Autodesk Building Design Suite Premium to give us access to Autodesk® Revit®. It was at around this time that NBS first released NBS Create for specification authoring; we could see the potential benefits of Uniclass structuring of specification data in a BIM environment, particularly when it comes to linking a specification system containing multiple products to a single BIM object. We found ourselves completely relearning how to produce and organise all of our design information, but believed it would be better to get all the pain over with sooner rather than drag it out through the gradual phasing in of new methods. I think that decision allowed us to get up to speed quickly and keep ahead of the curve.

We were quite lucky in the mix of projects we started out with. Most were quite large, with programmes that allowed us time to work out our new methods as we went, including developing BIM-like workflows for master planning. However, we had one smaller residential scheme that was to go through planning and on to the site reasonably quickly, so it was a good test-bed to see at which point we would run into difficulties with BIM or the new specification format. It seems odd thinking about it now, but there was a feeling that Revit would be good for general arrangements and schedules, but that anything more detailed than 1:50 would probably still be better handled in 2D CAD. That was certainly not our experience, and from the very outset we've found that we can produce 100% of 'drawn' design information across all project types in Revit.

The direction of travel towards BIM was quite clear, and it was also clear what the most used software platform would be, so we invested in Autodesk Building Design Suite Premium to give us access to Autodesk® Revit®.



The early projects highlighted a number of issues with working in a BIM environment for us. The first was quite obvious thinking back, but didn't occur to us at the time. Automation of tasks like scheduling and generating 2D views from the model meant that more senior architects authored more of the design information, so a greater proportion of architect time was spent, relative to assistant time when compared with more traditional working. The only issue was that working in a BIM environment from the very first sketch scheme forced more design issues to be considered earlier than they were traditionally. Clearly this is a huge benefit for projects, but combined with more senior staff working on projects for more of the time, this can really skew how fees are spent when compared with traditional project fee structures, and this is not something clients particularly appreciate at the moment.

In order to try and minimise the risks associated with spending too great a proportion of the fee earlier on in projects, we required some excellent reusable content, which really didn't exist in 2011/12. We made a decision not to fall into the trap of developing a massive practice library of BIM objects that would become a management headache to maintain. Instead, we have an essential library of generic objects modelled to just enough detail to look good for Stage 3 output. We also have object templates and reusable parts which can be quickly assembled into more generic BIM objects as needed for specific projects. We generally produce BIM objects for each project then review and decide if it would be worth keeping them in the library for future projects.

We see the NBS National BIM Library as an extension of NBS Plus and the specification authoring process.

The creation of the NBS National BIM Library was another development that was perfectly timed for our needs as the practice grew. As architects we were very used to writing NBS specifications, and for years we have come to rely on the quality of the content produced by NBS technical authors to ensure that our specifications are of a high standard and are technically accurate.

The integration of NBS Plus into specification authoring tools meant that it became easier and quicker to specify certain products. Quite simply, if we have two potential products to select from and only one is in NBS Plus, then we're going to need a very good reason to select the other product as it will take us longer to do so. We see the NBS National BIM Library as an extension of NBS Plus and the specification authoring process. The NBS National BIM Library is making it easier for us to use geometrically correct content that also carries the necessary data for future data drops as Level 2 becomes more widespread. We have tools available to check that IFC and COBie parameters exist and contain data, but we also need to trust that the data is consistently formatted and correct. We cannot check for errors automatically, so as with NBS Plus, we are much more likely to specify products that are in the NBS National BIM Library because we can trust the QA processes of NBS and know that the data is produced directly from manufacturers and to an exacting level.

It's straightforward to link BIM objects from NBS National BIM Library to our specifications via the NBS plug-in for Autodesk® Revit®

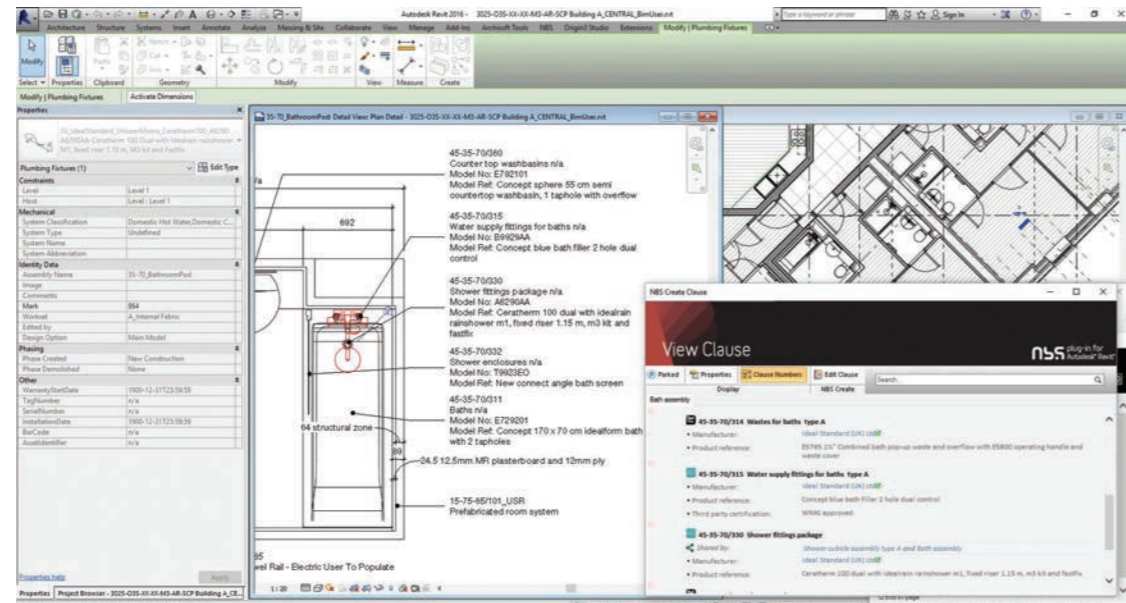

Of course on the internet there are several other free-to-access BIM object libraries which have very well modelled content. The first problem for us as Revit users is that we need the information in the object to be stored in the 'correct' shared parameters so that we can schedule and tag the content in our models seamlessly. By correct, we mean that the invisible GUID is the same, not just using the same name. Since the first release of the NBS National BIM Library, we decided that all of our standard schedule templates and annotation objects would display values stored in NBS parameters. This approach was further reinforced with the release of the NBS BIM Object Standard. All our object templates and generic objects have been pre-populated with the appropriate IFC and COBie parameters in the released NBS shared parameters file.

For any BIM content to be truly useful to us, the object needs to be developed to comply with the NBS BIM Object Standard, otherwise we're going to have to manually remap or replace parameters, which is a time-consuming process and one that could lead to errors in our information or important elements simply not appearing on schedules.

Historically, we probably had a tendency to keep 2D drawings fairly simple, and our specifications tended to read more as performance specifications. With the increasing performance requirements of buildings and increasing information requirements of clients, we're also finding that those elements are changing. Fewer of our specifications rely on performance clauses, and the increasing ease with which we can browse and select manufacturer content from within the NBS plug-in for Autodesk® Revit®, which means that we're moving from generic BIM objects and settling on actual product specifications, often quite early on.

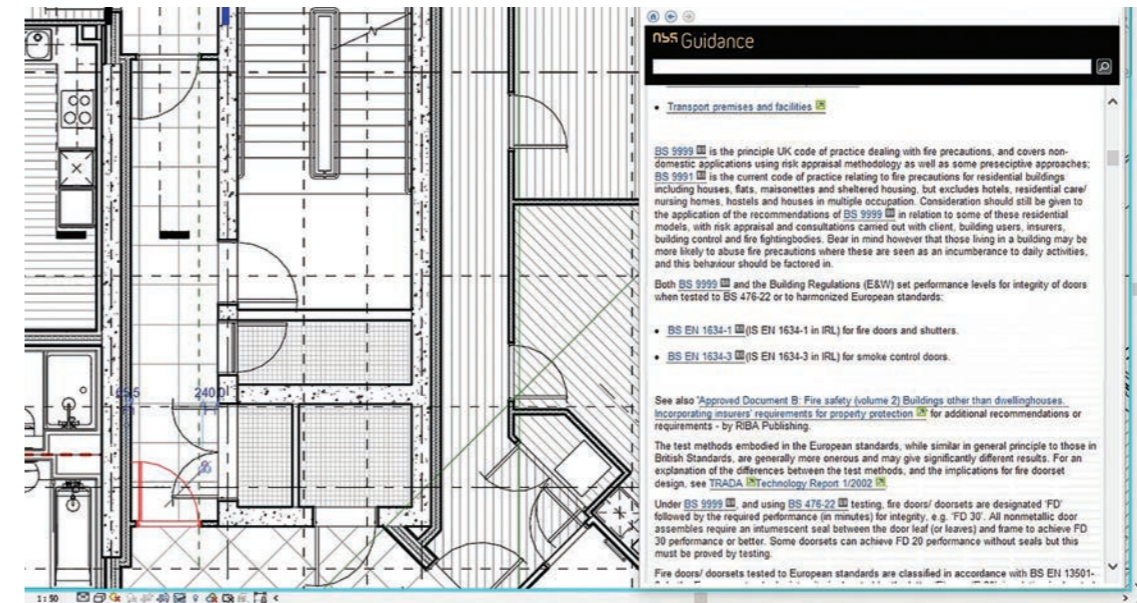

NBS technical guidance can be reviewed within Autodesk® Revit®, which aids the specification authoring process

As more products and generic content are added to the NBS National BIM Library, we are less likely to look elsewhere or create content in-house. In fact, we are increasingly looking to the NBS National BIM Library to select products. The NBS BIM ecosystem (the integrated suite of BIM tools and content) is becoming more integrated with Revit as the features of the Revit plug-in evolve, allowing us to drive the specification from our primary design tool and directly view the technical guidance and specification clause for selected BIM objects.

We keep coming back to a very simple message for manufacturers. More of our design authoring is happening at a more senior level where products are being selected and inserted straight into the model. We're not leaving specification writing to the last few weeks before tender issue anymore, so if you want us to specify your products and systems then you need to make it as easy as possible for us - and that means getting all of your products into both NBS Plus and the NBS National BIM Library.

More of our design authoring is happening at a more senior level where products are being selected and inserted straight into the model.

Presenting product information fit for BIM



Drew Wiggett
Head of Product Information, NBS



Architects have been delivering construction information, drawings and specifications for centuries, so why now the focus on the importance of 'data'? What has changed?

The emergence of BIM and VDC (Virtual Design and Construction) has allowed the industry to focus on how and for which purposes we use data.

I have worked in a number of architectural and design practices throughout my career. I've always been very engaged and have contributed to best practice for delivering construction data. Thinking back, each individual company had their own processes which worked well and served the desired purpose. However, time was often spent deliberating on the best approach to numbering drawing sheets or to standardising the amount of relevant data indicated on a drawing. I was often in discussions with contractors about how much information to include. Where did my responsibility end and that of the specialist designer begin?

I can specifically remember working in a framework arrangement with a number of other architects and delivering education projects with one contractor. Much of the data that the contractor received would have been different but should, in fact, have been the same. The contractor would have had to use this information for tendering and pricing analysis purposes: trying to align data that was very similar, but not quite the same.

The emergence of BIM makes these types of conversations and examples seem obsolete. We now have standards and tools to allow the consistent delivery of construction data, and the development of the NBS BIM Toolkit will assist in clarifying the level of detail and information required for a project.

Sharing product information

A key element for achieving this consistency of data is the way in which manufacturers make their product information available to the industry.

The sharing of product information is not new in itself. Like architects delivering construction information, manufacturers have shared product information for centuries.

I recall browsing the libraries of the practices that I worked for, flicking through catalogues of product information and searching for that nugget of information which would convince me to specify a certain product. Of course, times have moved on: manufacturers' catalogues are now digital PDF versions of the paper catalogues that I would have read. But do they satisfy the digital requirements of the modern designer working in the BIM environment? They are undoubtedly a good start and are easily accessible online, but designers are still presented with the challenge of interpreting the product information and deciphering the different terminologies used. This is where BIM can help.

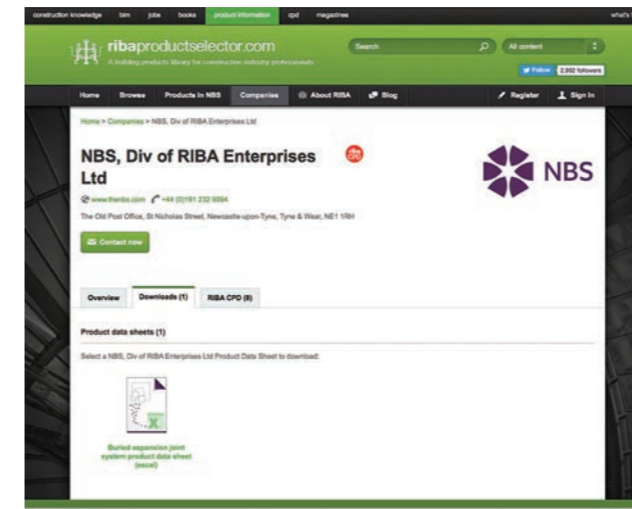

Completed manufacturers' product data sheets can now be hosted on ribaproductselector.com

Product Data Templates

BIM creates the opportunity for manufacturers to think about how they present their product information for use not only by designers, but also downstream by contractors and facility managers.

The BIM Task group called for product information to be presented within a standard product data sheet.

"Manufacturers who supply digital information to the industry are encouraged to make their information freely available in the form of a product data sheet which as a minimum should respond to the NBS 'data required' template and/or (where appropriate) parametric 3D BIM objects aligned to this template.

Manufacturers and product data templates are not limited by the 'data required templates' in the NBS BIM Toolkit and manufacturers can add further information to identify their key selling points e.g. to support analysis etc."

Source:
BIM Task Group Newsletter no. 45, July 2015

These product data templates were a key deliverable of the NBS BIM Toolkit and enable product information to be provided in a standard format. This product information can then be used by the designer to answer the client's requirements, by the contractor

for tendering purposes, and by the facilities manager for asset management.

The NBS BIM Toolkit website currently has over 5,000 product data templates, freely available to download and use. As stated by the BIM Task Group, these are the minimum information requirements for BIM Level 2, so manufacturers may wish to include additional information.

Once a manufacturer has populated a template with their information to produce a product data sheet, they should make it available for the industry to use either by promoting it on their own website or on product information websites such as ribaproductselector.com

The benefits for designers include easier collation of information and product comparison. Making the process smoother and simpler for the designer should, of course, be at the forefront of any manufacturer's mind.

The BIM Task Group also noted the opportunity for manufacturers to deliver 3D BIM objects. These objects, containing data as captured in a product data sheet, allow a designer to integrate the BIM object within a project model. Once integrated, information can then be extracted as required to satisfy the project data delivery requirements.

Why are 3D BIM objects more attractive to a designer than data supplied in a product data sheet?

The simple answer is that designers want a smooth workflow that doesn't involve reworking or stepping out of their natural environment. For a designer, this is very much about producing digital designs.

A designer wants to be able to drop a BIM object into the project model to see how it fits and integrates with its surroundings – is it the correct size, is there sufficient installation space, does it clash with adjacent features? Once an object is in place then the data interrogation and extraction can begin. Reports can be produced documenting the quantities and location of objects.

A key document for manufacturers to read is the [NBS BIM Object Standard](#). This document sets the national and international baseline standard on how to create BIM objects.

A designer wants to be able to drop a BIM object into the project model to see how it fits and integrates within its surroundings.

The **NBS National BIM Survey 2016** revealed that:

[Designers are looking to manufacturers to provide them with BIM objects. Seventy one percent agree that 'we need manufacturers to provide us with BIM objects'.](#)

The NBS National BIM Library has been developed as a key repository for manufacturers' BIM objects, allowing simple downloading and integration into a designer's workflow.

This is a very exciting time for the industry as a whole. The world has watched the UK move towards BIM adoption.

To allow this to continue, we must now work with the standards and guidelines that have been developed, and manufacturers need to fully engage with the process and produce product information that is suitable for BIM.

Digital Built Britain is the future of the UK construction industry.

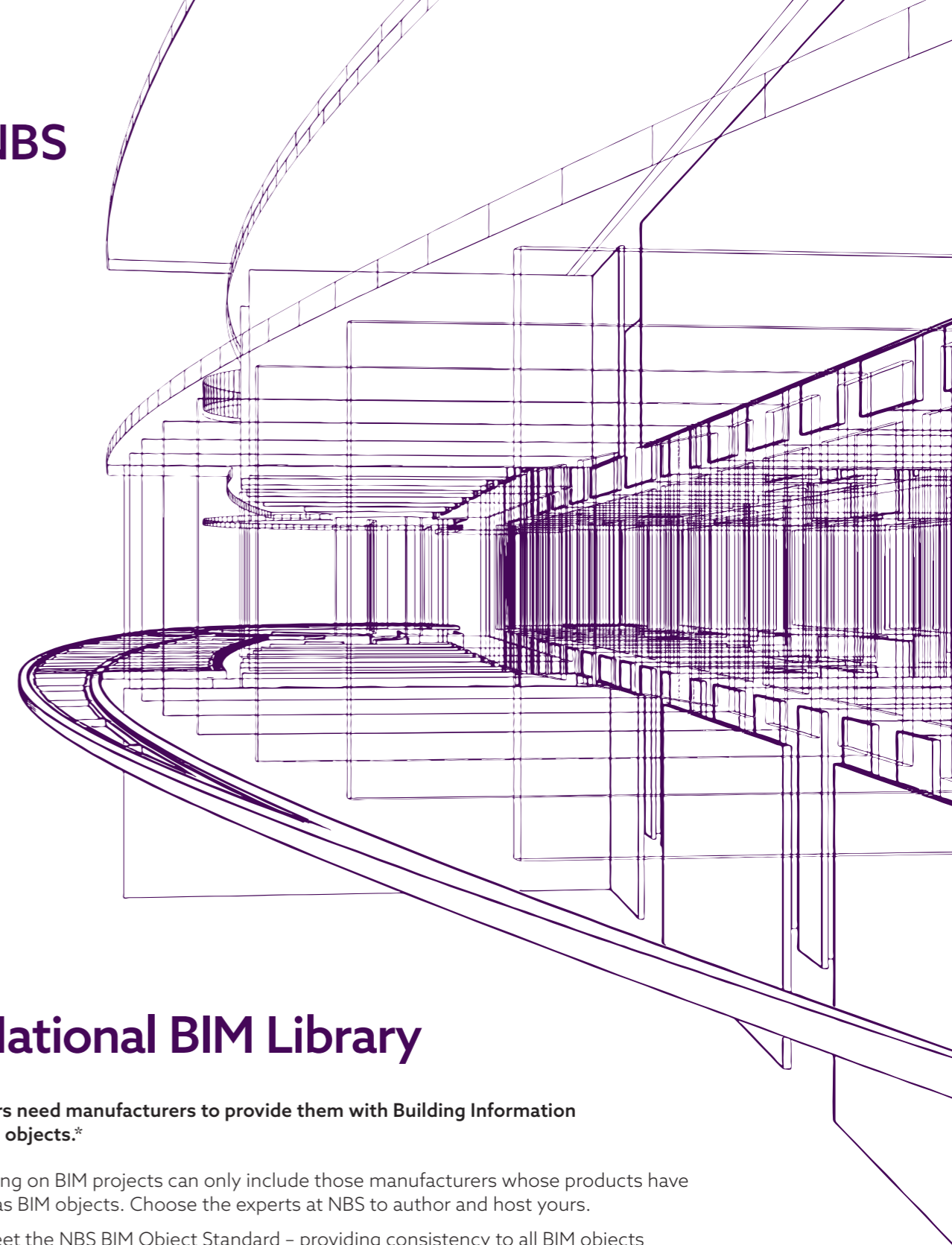

NBS National BIM Library

71% of specifiers need manufacturers to provide them with Building Information Modelling (BIM) objects.*

Designers working on BIM projects can only include those manufacturers whose products have been authored as BIM objects. Choose the experts at NBS to author and host yours.

- Created to meet the NBS BIM Object Standard – providing consistency to all BIM objects
- Available within the NBS BIM Toolkit – an integral part of the UK Government's BIM Level 2 package
- Hosted on [nationalBIMlibrary.com](#) – the UK's fastest-growing BIM library
- Directly integrated into the UK's leading specification software

Contact us today for a free, no obligation quotation

T 0345 200 1056 E info@riba-insight.com W [nationalBIMlibrary.com](#)

*NBS National BIM Report 2016. NBS National BIM Library for manufacturers is a RIBA Insight service.

Meeting the mandate – the Mott MacDonald story



Andrew Moulds
Associate at Mott
MacDonald



The strength of market forces and competition is such that there is an unrelenting quest to streamline process, minimise waste and promote effective working that continues to drive positive change in how organisations function, assets are managed and projects are delivered. Like many in the industry, Mott MacDonald has long identified Building Information Modelling as a differentiator to achieving this, with the UK Government lending its significant weight and influence through the Level 2 mandate to give focus and direction across the industry.

Owners of all classes of asset around the world, both existing and new, need to achieve greater performance from those assets to meet the increasing social need while reducing waste in terms of resources and cost, and being on hand to make this happen has been vital. Delivering an approach that accords with the mandate is now a prerequisite for working with the UK's public sector, but many aspects of the mandate have also proven good practice for how we function as an organisation of 16,000 people operating across 150 countries.

We recognise a need for our business to continually find ways of staying at the forefront, while our people want to work effectively with leading technology to avoid waste and duplication of effort. As global engineering, management and development consultants, our solutions need to be optimised to deliver sustainable outcomes. BIM is integral to delivering all of this.

The times of early exploration a decade ago saw varied success, but the advent of our vision in 2010 (where it would become an integral part of the way that we do business) has proved to be accurate.

More recently, our efforts have focused on accelerating change through implementing strategic actions as an integral part of good practice and management policy in all parts of the Mott MacDonald Group, and to develop an enhanced service offering to help customers and asset owners realise the full potential benefits of BIM through better outcomes.

As global engineering, management and development consultants, our solutions need to be optimised to deliver sustainable outcomes. BIM is integral to delivering all of this.



Internal endeavours

A continual programme of technological improvements has been critical in delivering the step change required by the mandate. This was led by a central Project Technologies Group, under the stewardship of the Group BIM Steering Committee, which was informed by direct input from champions across the business. 2015 marked the completion of two corporate technology solutions: the Mott MacDonald Common Data Environment (MMCDE) and the Digital Component Catalogue (DCC) aim to cement our capability of delivering projects to meet BIM Level 2.

After over seven years of developing, implementing and operating BS1192-compliant Common Data Environments (CDEs) on some of the world's biggest engineering projects, we have used this experience to develop a standard corporate approach which is available group-wide for immediate project mobilisation.

Throughout the development of the MMCDE, we have engaged senior, leading personnel to shape an approach to information management across our core technical sectors that results in superior outcomes. Hosted on Bentley's ProjectWise, these requirements have focused on balancing the needs of our integrated management system for quality, environment and safety, and for projects that use our globally diverse Autodesk and Bentley user communities.

The DCC is a technology solution that aims to efficiently produce high quality digital deliverables. Again using ProjectWise to support all of our users, we have developed a system for making our digital content (such as BIM object families) available to all users through a single location.



Find out more about the NBS BIM Object Standard at nationalBIMlibrary.com/nbs-bim-object-standard

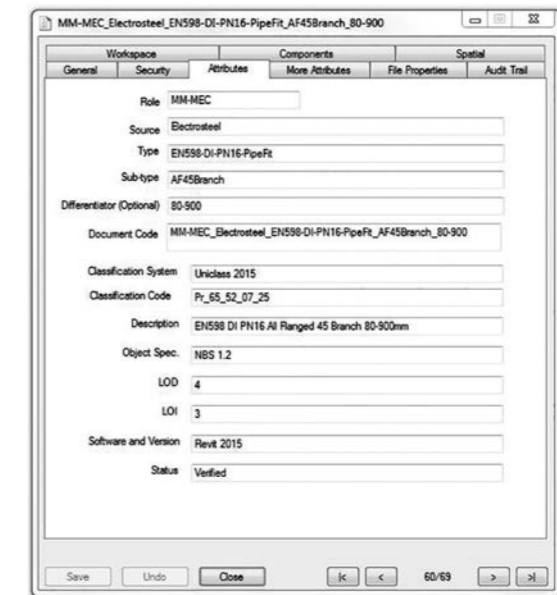

Example of standard ProjectWise attributes for all elements in Mott MacDonald's DCC using the NBS BIM Object Standard, Uniclass 2015 Classification, and separate Level of Detail (LOD) and Level of Information (LOI).

Adoption of the [NBS BIM Object Standard](#) has been important as it defines requirements for both graphical and non-graphical information and can be consistently applied across multiple sectors, regardless of the authoring package. This was seen as a key requirement for having a standard approach for digital components that will add long-term value to the business to service thousands of international users.

The DCC already contains over 4,000 objects which can be used on any project, and the content continues to grow as more is created on projects. This centralised and standardised approach to objects is resulting in higher levels of consistency in deliverables and more efficient production of BIM deliverables.

The DCC and MMCDE are both critical aspects in supporting our wider investment in and thinking about Design for Manufacture and Assembly (DfMA).

Roebuck Service Reservoir: rendered 3D model and 2D drawing that use content from the DCC. The drawing output includes schedule tables that are created using only object metadata, demonstrating the efficiency of adopting the NBS BIM Object Standard through the standardisation of the data structure

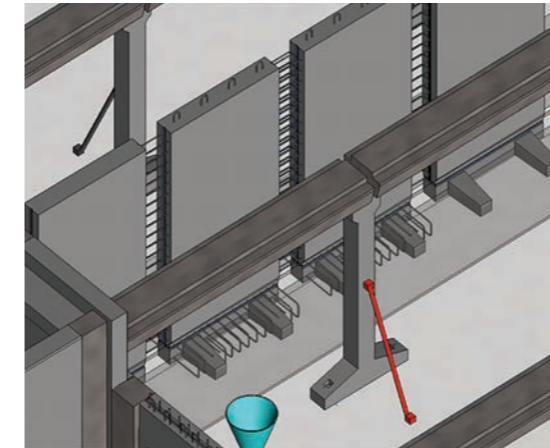
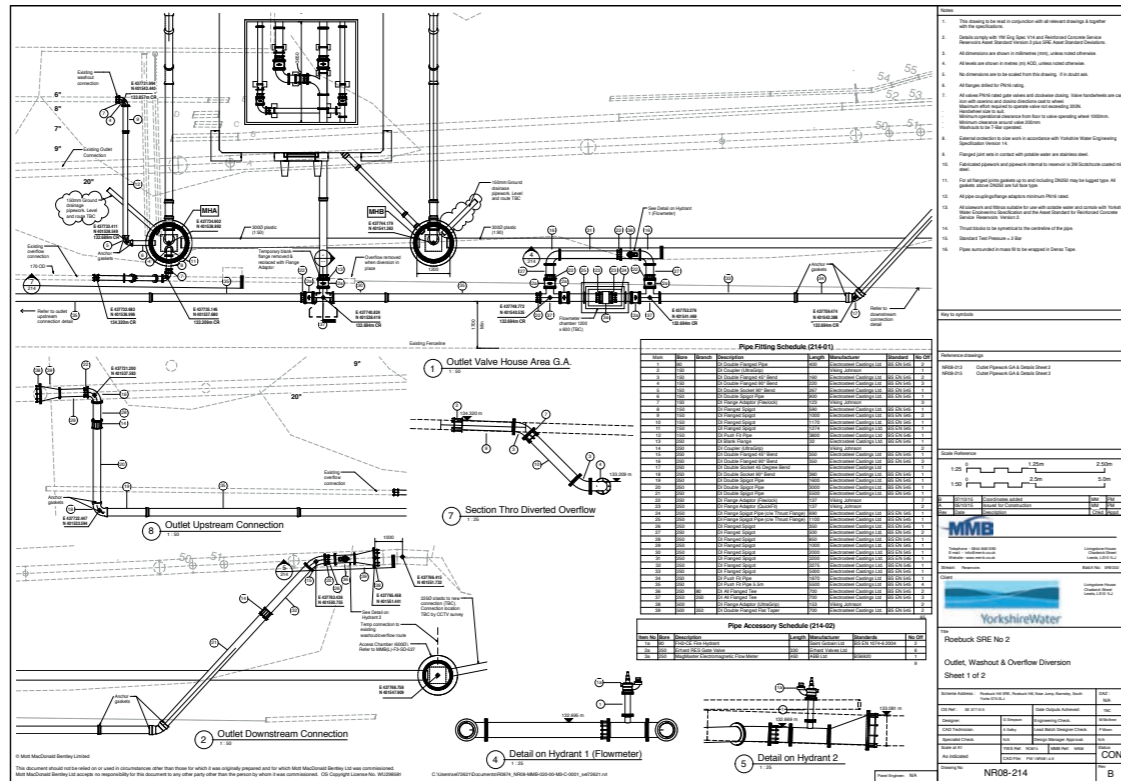
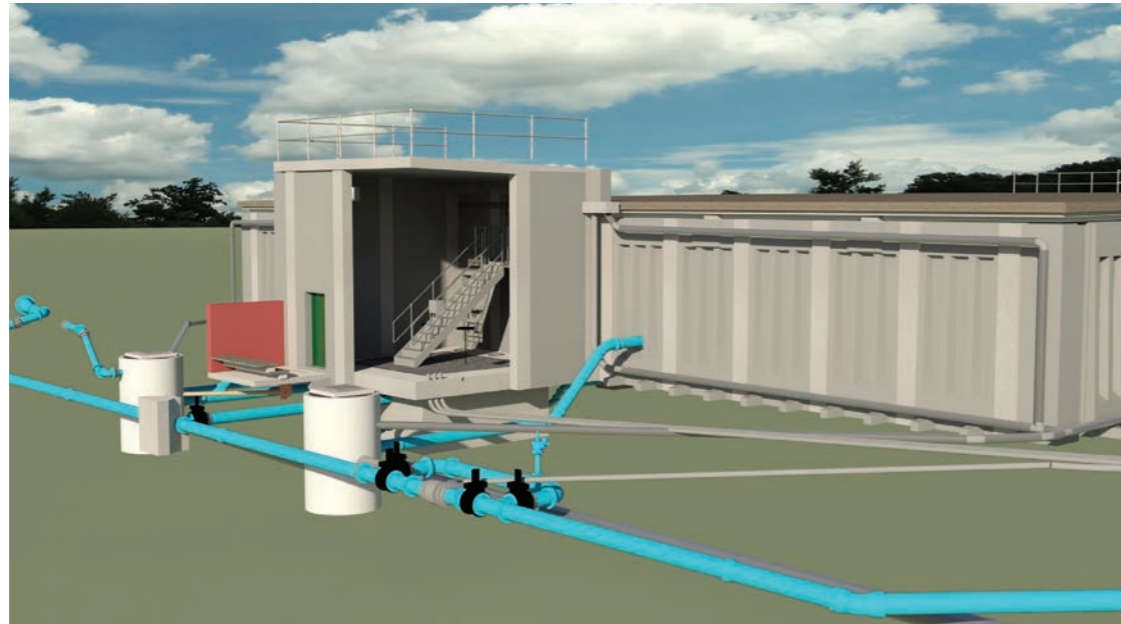

An example of the 3D components authored for Carlow Precast. The walls show the rebar, which is useful for checking clashes, and the support column shows the temporary prop, and also enables site teams to understand access requirements.

Design for Manufacture and Assembly

As part of Mott MacDonald Bentley (MMB)'s role in delivering Yorkshire Water's AMP6 Framework, we began working with Carlow Precast by elevating the existing workflow (that consisted of obtaining their 2D layout drawings) and converting them into 3D models. As time progressed, MMB built many of Carlow's standard pre-cast components as 3D library elements - adding in details such as the reinforcement to the edges. This helped enormously in coordinating the designs and preventing unforeseen design issues from leading to costly downtime on-site. The libraries have gone on to be used in many other reservoir projects and also for other clients such as United Utilities and Severn Trent Water. The return on investment in creating these initial libraries has been significant.

Carlow quickly grasped the advantage of these model 3D library components. They have now invested in their own 3D system (Autodesk® Revit®) and are working on producing their entire catalogue in a 3D format. MMB see this as a significant step forward in the Design for Manufacture and Assembly (DfMA) process. Accuracy of the model elements now lies with the manufacturer, removing the requirement for MMB to remodel second-hand data and the potential for dimensional errors to be introduced. Carlow plan to create their entire catalogue in 3D - not just the reservoir components - so the advantages realised in reservoir design could spread to other types of projects.

Mott MacDonald Bentley, along with Carlow Precast and Yorkshire Water Services, has been shortlisted for the ICE Yorkshire and Humber Awards 2016 for the Watersheddles Reservoir Spillway Improvements project in Keighley.

The future intention of the MMB/Carlow collaboration is to include further metadata within the 3D components. Carlow have recently developed a digital manufacturing tracking process. Where previously each component would be tied to a set of paper documents, and signatures and information would be accumulated throughout the manufacturing process, they have now introduced a digital process where the information is stored digitally and accessed by barcode or sensor. It is feasible that much of this data could then be embedded into the model components. Weights, concrete test results, manufacturing dates, sign-offs, carbon content and other information could be linked to the components so that this data could be used to resolve any issues during the design process or on-site. Individual component identification codes could also assist the site teams in ensuring that the correct components are stored in the right locations.

BIM has undoubtedly expedited the integration of design-manufacture-construction stages in a more holistic way that is delivering better project outcomes for both end-user clients and their supply chain teams alike.

If this information is then added to during the construction process, such as COBie data to include installation dates and warranty periods, we begin to see how the model can become a rich source of knowledge long after the project is completed.

MMB are also hoping to collaborate with other manufacturers, such as ElectroSteel, whose ductile iron pipework component library we have already created and used on the Roebuck Reservoir and other service reservoirs, and also on the Rivelin Sirofloc project for Yorkshire Water. In the future, we would hope to see ElectroSteel manufacture its own component library and begin the process of providing enhanced data within their products.

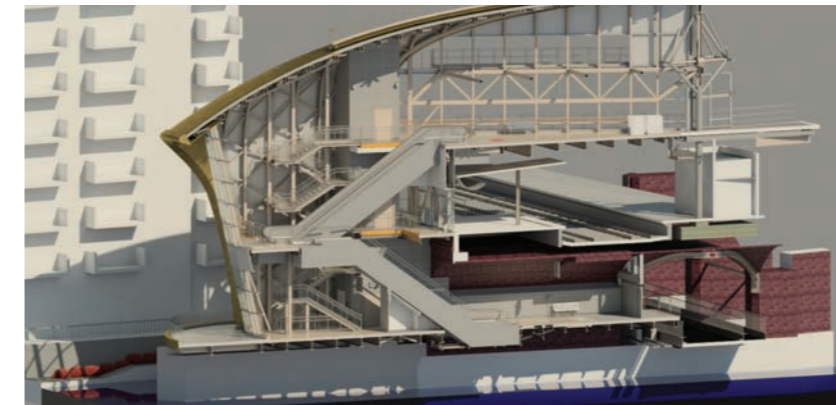

Leeds Station Southern Entrance:
rendered 3D section

“The job looks fantastic and our stakeholders were delighted. A few commented to me what a challenge it must have been to build.”

Rob McIntosh,
Network Rail Route Managing Director

Leeds Station Southern Entrance

Our BIM story is one of continual evolution that is founded on a reputation for technical excellence and commercial success, delivered consistently across most of our markets. Our award-winning heritage grows ever stronger, having won international accolades including those awarded by Fiatch and the National Construction Computing Awards.

The new Leeds Station Southern Entrance (LSSE) is one of our latest, leading engineering projects. It is a landmark scheme designed to improve access to the station from the south of the city. The complexity of the over-river site environment, the adjacent tower blocks, the structural form, interfaces and stakeholder liaison process was only really possible through the effective use of BIM tools and processes.

Models across all disciplines were federated and used to generate clash reports, which were used to replace the traditional paper workflow used in Network Rail's Integrated Design Check (IDC) process. This offered a significant reduction in the time required for this process, allowing key issues to be identified and resolved in an expedient manner, rather than via a paper-based review of deliverables. Network Rail's asset managers were a key consultee, given their requirement to be able to undertake a touching distance inspection of all bolted connections every five years, meaning that careful consideration had to be given to all details to allow access.

The model was also used as a visualisation tool for allowing virtual reality walkthroughs to clearly communicate issues and obtain project sign-off.

The federated model also proved critical in managing the construction interface. Model information was exchanged with the fabricator and cladding subcontractor, who augmented and enhanced the level of detail to construction status. Rebar was modelled in critical areas, and the construction sequence was animated to communicate the design intent and buildability to the site teams, with regular health and safety workshops held to explain how elements were to be erected on the constrained river deck site.

BIM has undoubtedly expedited the integration of design-manufacture-construction stages in a more holistic way that is delivering better project outcomes for both end-user clients and their supply chain teams alike. The ball is firmly rolling in a positive direction, and we expect the pace to increase as we move through BIM Level 2 and towards Level 3 over the coming years.

BIM Survey: The findings



Adrian Malleson
Head of Research,
Analysis and
Forecasting, NBS



In April this year, the Government's mandate for Level 2 BIM came into force. Now, any project for the public sector that is funded by central Government will need to be done through collaborative 3D BIM. In this report, we look at the findings of the NBS National BIM survey to uncover what the rise of BIM means for construction product manufacturers.

More than 1,000 people responded to the survey, making it the most accurate picture of BIM adoption and usage within the UK. The findings of the survey reveal that during the five years since the former chief construction adviser, Paul Morrell, set course for Level 2 BIM as part of the Government's construction strategy, the UK BIM strategy has been largely vindicated. You can see the full findings of the survey here: thenbs.com/knowledge/national-bim-report-2016

The survey explores the view of the design community. It is the design community, in part spurred by the government mandate, that has been leading BIM in the UK. By looking at the findings of the report, we can see what designers need from construction product manufacturers.

Overall, the picture the survey paints is positive for the Government, and for proponents of BIM working. In the years NBS has been running the survey, BIM adoption and use has transformed from a niche practice into a standardised design methodology used by a majority. Of those who have adopted BIM, only 6% say they wish they had not, and a majority say BIM improves client outcomes and brings cost efficiencies.

BIM is collaborative. Any significant construction project will involve a number of parties, including the client, designers and contractors as well as construction product manufacturers. In a successful BIM project, these parties will be working together within a BIM environment. Indeed, working within a BIM environment will increasingly become a condition of being part of the design and construction team.

For construction product manufacturers, working with designers is often a collaborative process. This may be through providing product information, exploring design possibilities opened up through innovative products, or through more formal channels such as CPD.

Product substitution has always been a threat to the work manufacturers carry out with designers. Whilst getting a product specified by a designer is a route to product purchase, products can be substituted through contractors' 'value engineering'. BIM will not stop this happening, but it will allow greater levels of product information to be made visible through the construction timeline. This information can allow the criteria for product selection to be made clear, and the defence of product selection easier.

Manufacturers can typically provide product information through BIM objects and product information sheets (based on, for example, the product information templated in the NBS BIM Toolkit). These are significant steps to exposing much needed technical product information to the design and construction teams.

BIM will allow greater levels of product information to be made visible through the construction timeline.

BIM usage

A majority of designers now use BIM, and adoption is set to rise rapidly over the coming years.

Fifty-four percent tell us that they are currently using BIM. Forty-two per cent are aware of BIM, though are not using it. A mere 4% are unaware of BIM. This is significant. BIM has become a routine way of designing and constructing buildings. When we look back to 2011, only 13% of people were using BIM, 45% were just aware of it, and 43% did not know what it was. Whilst the rate of adoption has moderated, we have come a long way.

The survey also allows us to look forward. By asking respondents whether they will use BIM in the future, whether next year, in three years' time or in five years' time, we can project future BIM adoption.

Designers expect that BIM will become near universally adopted within three to five years. Of those who are aware of BIM, 86% expect to be using BIM by this time next year, and 97% within five years. Three quarters see it as 'the future of project information'. Whilst perhaps not all who intend to adopt BIM will do so in the time anticipated, the direction of travel is clear. We can expect BIM adoption to increase dramatically over the next few years.

BIM is already required for public sector work. The Government requires BIM because it means buildings are built more cost effectively and can be maintained more efficiently. This is why the Government is already seeing significant cost savings through BIM and is making further investment in it.

As the benefits to the UK's largest client, the Government, become clear, clients in the private sector will increasingly demand BIM too. Therefore, we can expect BIM to become increasingly demanded. It is a demand only the BIM-ready can respond to, whether designers, contractors or product manufacturers.

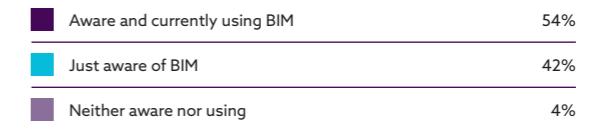

Projection of BIM usage among those aware of BIM

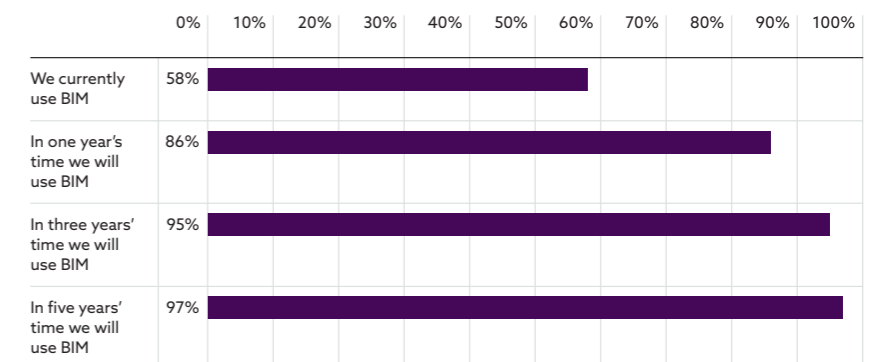



Finding out about BIM

Designers looking to adopt BIM need to acquire the skills and knowledge to do so. They are looking for help with BIM. Significant numbers feel they lack skills and knowledge in BIM.

Whilst almost half (48%) tell us that they are 'very' or 'quite' confident in their knowledge and skills in BIM, the majority of respondents tell us they are not. Nearly a quarter (23%) describe themselves as 'in between', whilst 28% tell us that they are either 'not very' or 'not at all' confident in their BIM knowledge and skills.

BIM can often seem like an exclusive club, made up of only those with detailed skills and knowledge. This can make those who are starting with BIM reticent to explain what they can offer through BIM. Manufacturers may feel that they are on the back foot when talking about BIM to designers. There is no need for this. Many designers lack confidence in BIM and are looking for help and information. They value manufacturers as collaborators in realising design intent, and will look to manufacturers to continue their role as product experts within a BIM environment. However, BIM will mean that manufacturers will increasingly need to deliver product information in different, more structured formats.

How confident are you in your knowledge and skills in BIM?

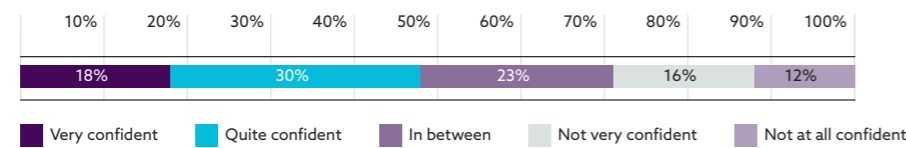

Manufacturers may feel that they are on the back foot when talking about BIM to designers. There is no need for this. Many designers lack confidence in BIM and are looking for help and information.

BIM objects

BIM objects are the building blocks of any good Building Information Model. BIM objects are the digital representation of the products and systems that make up a building. Well-formed BIM objects (not all are well formed) contain the information designers need, both about the geometry of a product, as well as its attributes. The NBS BIM Object Standard describes how objects can be consistent in their content and structure so that they can be well formed and useful to designers.

"The construction industry needs access to BIM objects that can be used freely, safe in the knowledge that they contain the right levels of information with the appropriate geometry, all wrapped up in a consistent, yet structured and easy to use format."

Richard Waterhouse,
CEO, NBS and RIBA Enterprises

"Adoption of the NBS BIM Object Standard has been important as it defines requirements for both graphical and non-graphical information and can consistently be applied across multiple sectors, regardless of the authoring package."

Andrew Moulds,
Associate at Mott MacDonald

Where do you get the BIM objects your organisation uses?

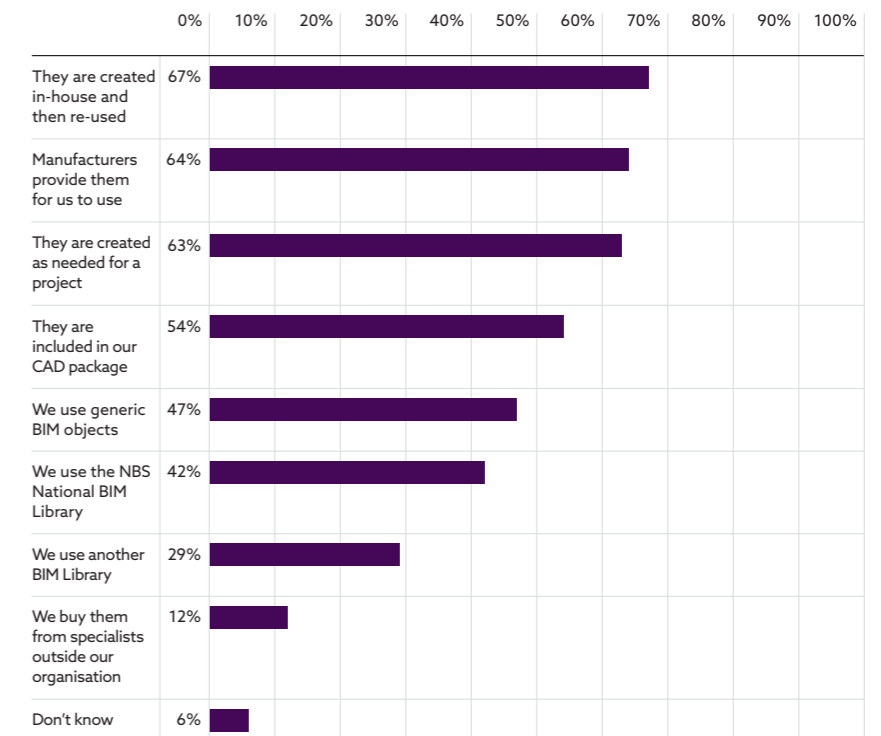



The NBS National BIM survey found that the design community continue to obtain BIM objects from a range of sources. Sixty-seven per cent create objects in-house and then re-use. Sixty-three per cent create objects as needed for a project. These methods are inefficient and risky. In-house creation leads to significant duplication of work among the design community, with practices creating their own versions of common building components. It also adds risk, through errors in object creation and in re-use of objects that may have become out of date or superseded. It takes time and skill to create objects: time and skill that may be better used elsewhere.

Significantly, if Intellectual Property sits within a practice's library of BIM objects, this can become a barrier to collaboration.

A better way is to author objects once, and use them many times. Even better is if these objects follow a standard format. The NBS National BIM library allows that to happen. Through it, manufacturers can create well-formed, standardised BIM objects that are made freely available to the design community. This approach eliminates duplication, reduces risk, and allows manufacturers to be certain their objects hold the information designers need.

Designers understand this and are looking for more BIM objects to be available to them, rather than having to create them in-house. Designers are looking to manufacturers to provide them with BIM objects. Seventy-one per cent agree that "we need manufacturers to provide us with BIM objects".

We need manufacturers to provide us with BIM objects

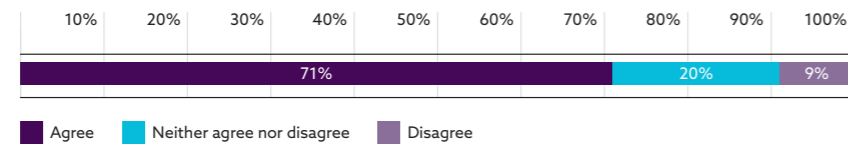

Designers are looking for more BIM objects to be available to them, rather than having to create them in-house.

Government policy and beyond the UK

The BIM mandate emerged from the government construction strategy. At its heart are four important targets:

- lower costs;
- faster delivery;
- lower emissions; and
- a reduction in the trade gap for construction products.

In the NBS National BIM survey, we asked designers whether they feel that BIM will help the UK construction industry reach these targets. The majority believe that BIM will for two of them:

- Lower costs: 63% tell us BIM will help bring about a 33% reduction in the initial cost of construction and the whole life cost of built assets.
- Faster delivery: 57% tell us BIM will help bring about a 50% reduction in the overall time, from inception to completion, for new build and refurbished assets.

Fewer (39%) believe that BIM will help achieve a 50% reduction in greenhouse gas emissions in the built environment. Less than a third believe that BIM will help reduce the trade gap between total exports and total imports for construction products and materials.

This last one is worth a closer look, however. Having standardised product information delivered through BIM objects makes it easier to deliver product information in other countries where BIM is being adopted. The NBS International BIM Report (thenbs.com/knowledge/nbs-international-bim-report-2016) explores the rise of BIM in several countries across the world, including Japan and Canada. In the EU, an increasing number of countries are adopting BIM, encouraged by central government.

"Europe is now host to the greatest regional concentration of government-led BIM programmes in the world. Finland and Norway were first to set standards, followed by procurement policies from the UK, Netherlands and Italy; and most recently joint government and industry initiatives from France, Germany and Spain. Europe's central policy and governance function, the European Commission, endorsed BIM as an enabler for delivering public works by encouraging its use in the EU Public Procurement Directive (2014)."

Adam Matthews,
Chairman of the EU BIM Task Group

The relative maturity of UK BIM and the rise in BIM adoption globally presents an opportunity. Becoming BIM-ready for the UK is a significant step towards being BIM-ready globally. It is an opportunity to capitalise on the UK's strong position.

Please tell us the role you think BIM will have in our achieving the following:

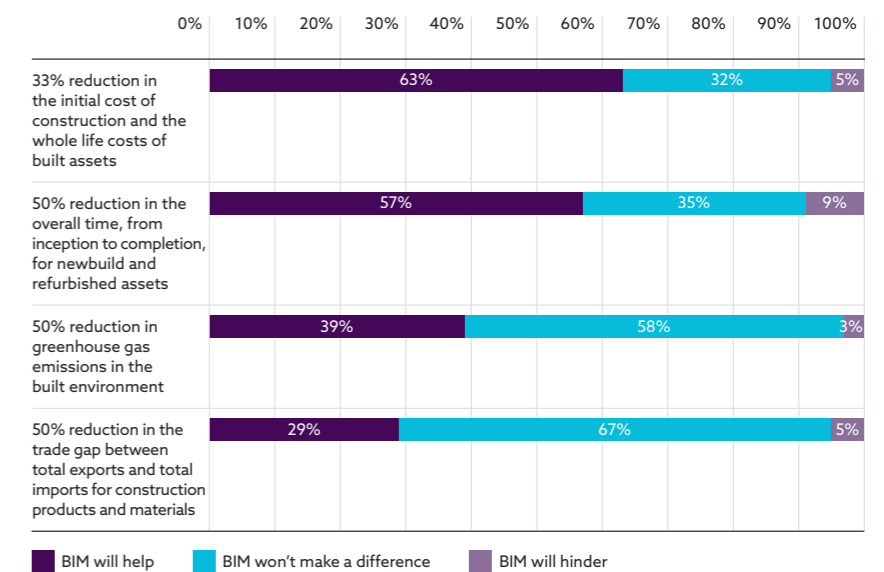

End note

“BIM is the future. It is the way the coming generation will work. It will radically change the way we would go about our roles.”

In the six years we have been running the BIM survey, designers have told us that ‘BIM is the future of project information’. We are now seeing that future become a reality. With the BIM mandate coming into force, the broad adoption, use and development of BIM will continue as the public sector demonstrates the value of BIM.

This provides a real opportunity to construction product manufacturers. Through working with designers in a collaborative BIM environment, in part through providing well-structured, standardised BIM objects, manufacturers can efficiently deliver product information to the design team when, and how, they need it.

Through working with designers in a collaborative BIM environment, in part through providing well-structured, standardised BIM objects, manufacturers can efficiently deliver product information to the design team when, and how, they need it.



Are you BIM Ready?

Place your products as BIM objects directly in front of construction professionals at the time of specification

The NBS National BIM Library is the UK’s fastest-growing BIM library. It leads the way in authoring high quality BIM objects for manufacturers, which designers can use throughout their project work.

NBS BIM Object Standard

We will author or certify your objects to meet the NBS BIM Object Standard – created to enable greater collaboration and provide consistency to all BIM objects and your assurance of high quality.

Authoring

Our NBS experts can author your BIM objects to meet the trusted NBS BIM Object Standard. We work closely with you to determine what product information to include.

Certifying

Create your own BIM objects and our experts will assess them to certify that they meet the NBS BIM Object Standard. Detailed guidance is available for manufacturers who wish to create their own BIM objects.

Availability

Your BIM objects are hosted on NBS National BIM Library and made available within the NBS BIM Toolkit where they can be accessed by thousands of architects and other specifiers working on BIM Level 2 projects.

Integration

Designers can locate, download and use your BIM objects in their projects via our unique and innovative NBS Plug-in for Autodesk® Revit®.

Exposure

Choosing NBS National BIM Library to host your BIM objects will maximise your exposure to specifiers and designers across the industry. You can also sync your objects to your own website to further increase their visibility and use.

Analytics

See at a glance how your BIM objects are performing with our analytics tool. Download reports on individual objects, and see which practices are viewing and downloading your objects and from which geographical locations.

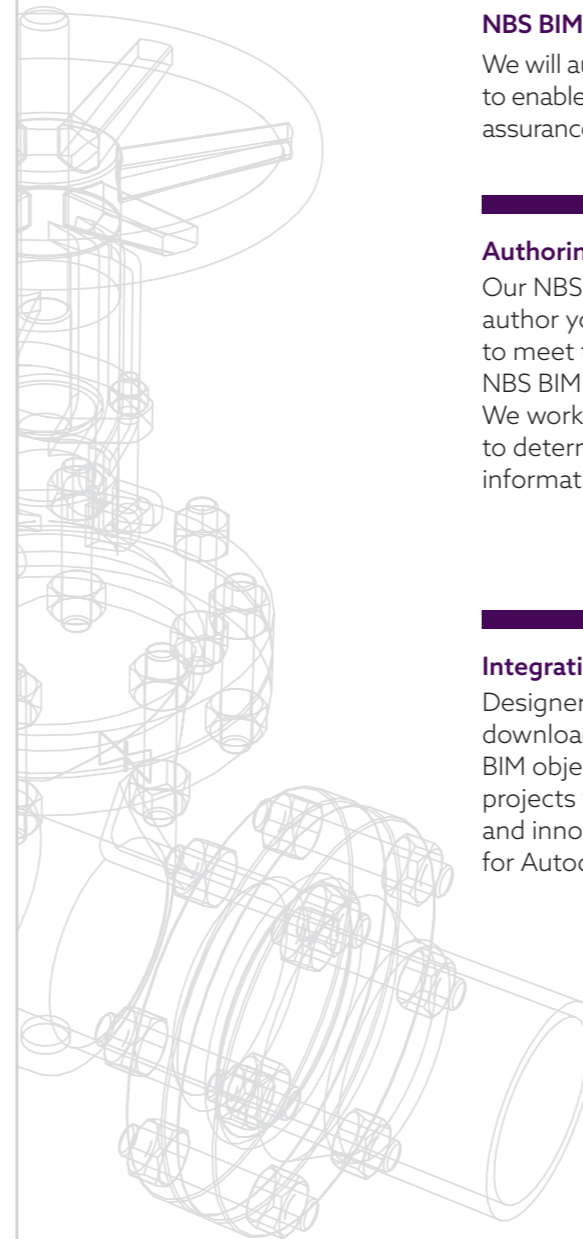

Find out more about how we can help you take the next step on your BIM journey with our range of BIM services and tools.

**T 0345 200 1056 or E info@riba-insight.com
nationalBIMlibrary.com/BIM-for-manufacturers**

BIM and the manufacturer



Vicky Evans
Managing Director,
Twinfix



Embracing the future with BIM

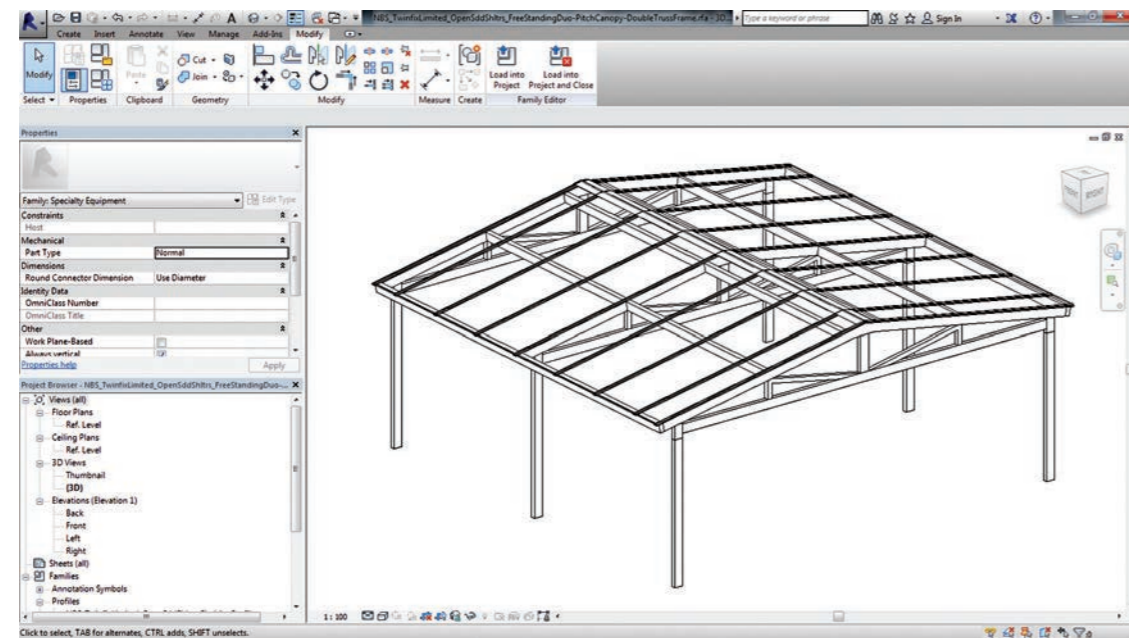

My first thoughts on hearing about BIM (Building Information Modelling) were: how is this going to work? A great concept in theory, but how will the practicalities work and will it help drive efficiencies, or will it just be more work? We all work in high-pressure environments where time is money, and we must look at which activities add value and which do not. Certainly for a relatively small manufacturer like ourselves, we need to be careful when deciding what we sign up to, so my initial thoughts on BIM were somewhat reserved.

The idea of a model showing every detail of a building which can be manipulated seemed very science fiction. It led me to wonder how it would work in practice and whether specifiers and the industry will actually use it.

Our BIM journey began with the BIM day in Manchester and embracing the BIM challenge. I embarked on the two-day conference with mixed feelings. However, it was soon apparent that BIM was exciting and, although challenging, was fundamentally an efficient and forward-thinking way of constructing a building. I began to feel excited by this new and challenging prospect.

So, as I began to learn about this new concept, terms like COBie (Construction Operations Building Information Exchange) began to make sense. I quickly started to understand how BIM could benefit us, both at specification stage and throughout the whole design process. I felt assured that the upfront work needed for BIM would have long-term gains. Preparing the objects that contain the information you need means less rework, less duplication and a much smarter way of working. As we all know, working smarter is the sensible way forward.



Canopy in situ at a school



In-house manufacturing

So we embraced the concept and commissioned NBS to author our canopy products. They worked with one of our in-house designers to construct our rather complex models, understanding how our canopies worked. Once completed, I went into the webinar where NBS demonstrated our products with bated breath, concerned about how they would look. I need not have worried as they worked better than anticipated. In fact, the result was a good-looking, rather clever object that was easy to understand and manipulate.

I believe we are the first canopy manufacturer to have these objects and I'm very proud that Twinfix took this bold step.

The future is here. We have BIM. We have a 3D printer. And most importantly, we are a British manufacturing company embracing the future... How exciting! The science fiction that I believed BIM to be is now very much a reality.



3D printer

I quickly started to understand how BIM could benefit us, both at specification stage and throughout the whole design process.



Andy Duck
Marketing and
Communications
Manager, Bruynzeel
Storage Systems



Our route to BIM



Compactus Mobile Shelving SHADE by Jacob Jensen – one of five Bruynzeel products available as BIM objects – installed at Coventry University, September 2015. Photo: Simon Hadley

Bruynzeel Storage Systems is a Dutch manufacturing company with sales offices in nine European countries, and more than 30 dealerships worldwide.

Although a relatively small part of Bruynzeel's global operations, when it comes to BIM development, the UK office is leading the way. This is not so surprising. Our largest markets in mainland Europe – Germany, France and Scandinavia – are a couple of years behind us in terms of BIM adoption. They do not have the same imperatives that the UK construction industry is facing thanks to the deadlines and structural imperatives imposed by the Government's BIM task force.

Bruynzeel's existing processes for creating specifications and drawings are set centrally and rolled out to all territories. We use an integrated system for drawing, specification and billing. Altering this system was not practical in the short term to create BIM models in Revit, so Bruynzeel looked

externally for the expertise to provide BIM-ready models that met the relevant object standards.

In the UK we wanted to make the design and configuration of our systems more accessible for architectural practices and other third parties. We believe BIM objects are a good route for practices to configure systems within our current product standard specifications. Our thinking in the UK office is that by investing in BIM now – testing the waters with a few products – we can help to influence the Bruynzeel Group and gradually draw the company towards fully integrating BIM into Bruynzeel's systems over the next few years. Ultimately, we see BIM as having a significant impact on internal processes in the medium term.

It was against this background that we approached NBS in the latter part of 2014 to begin the process of creating our first BIM objects for five of our most popular shelving products.



Process

Bruynzeel's Craig Rumbold explains: "I created a 2D AutoCAD drawing of all standard sizes applicable to the models – for five of our most popular products – and a walk-through of our approach to configuring a system from scratch. In essence this included the length of the base, the height, and then the additional details such as number of loaded levels and bay types." These details were sent to NBS, who then began work on transforming our guidelines into the finished BIM objects.

Bruynzeel products are not simple, discrete objects. Originally we were talking about patching the complex object together from its component parts. However, during the process NBS suggested we could have one configurable model which included all the essential variables for a complete object. This speeded up the process of object creation, and meant our financial and time investment at early stages was kept to a very manageable level.

Bruynzeel systems are pretty much bespoke. We can offer almost limitless configurations, so by condensing – or consolidating – the objects a few sacrifices had to be made. For example, in our BIM objects shelves are always equidistant within a bay and do not contain individual configurable clearances.

"The idea was to have accessible 'placeholder' models for architects to use in existing project plans that are Level 2 BIM compliant," said Rumbold. "Although our models carry the necessary information for creating NBS tender specifications, ultimately a designer or architect will still need to contact Bruynzeel for finalising specifications and pricing."

We chose to keep the models 'white' in order to keep them as 'light' as possible for end users adding them into larger project files. Keeping the models white also means designers have the option to select colours and designs from our standard colour charts or add specialised finishes in keeping with their overall project concept.

Looking to the future

To date, we have only created BIM objects for a selection of our mainstream products. They lack a large number of accessories and some of our specific options, plus unique products like our racking and double decker systems are yet to be added to the NBS National BIM Library. So we're a long way away from offering BIM objects on our complete range. "Our BIM endgame would be to have every element of every product as a BIM object, provided computer processing speeds can continue to improve to enable any large-scale architectural plans that result to be sufficiently portable and manageable..." said Rumbold.

Overall our BIM objects provide a level of detail that was previously unavailable in 2D AutoCAD 'blocks'. The new objects contain stoppage distances between mobile shelving, for example.

"When an architect or designer uses our BIM objects, the result is a much greater level of accuracy at early design stage," said Rumbold. "This undoubtedly corresponds with increased efficiency of process – one of the outcomes BIM has always hoped to achieve."

In the UK we wanted to make the design and configuration of our systems more accessible for architectural practices and other third parties. We believe BIM objects are a good route for practices to configure systems within our current product standard specifications.



Edward Rose
BIM Project Leader,
Ecoprod



Ecoprod Technique



URIMAT Waterless Urinals as specified by McDonald's Restaurants Ltd

Towards the end of 2014 and into early 2015, the team here at Ecoprod became increasingly aware of the 'BIM Movement', as I like to call it, primarily through our contact with architects and specifiers but also other influencers such as M&E consultants and contractors.

Although there was, is and continues to be much discussion around BIM, we quickly realised that we needed to take this change seriously, as it was being driven by a clear mandate from the UK Government in relation to public sector projects from 2016. The government mandate was a deciding factor for us, regardless of what others were saying about BIM; plus subsequently the May 2015 elections proved that this was unlikely to change, at least until 2020. A lot of specification of products would happen within this period! Change was clearly happening or about to happen in the specification of products and we needed to align ourselves with it or our products were unlikely to be included in live projects.

We also realised that this would become the standard for all projects, both public and private sector, as the benefits of BIM are the same, no matter who the end client is or who they are employing. As an importer and distributor, we come under the classification of a 'Product Manufacturer'. The UK was clearly leading the field globally as a direct result of



Miscea CLASSIC 3 in 1 touch-free sensor tap with two integral dispensers - available as a BIM object on NBS National BIM Library

the UK Government's mandate. Given the fact that we were representing the leading brands of URIMAT and Miscea within the UK, we decided that if we expected those products to be specified for all types of projects going forward, and not just within the UK, we needed to be on the platform before the train arrived!

Therefore, I was tasked with researching 'all things BIM' and given a target of being 'BIM-ready' for all the main products before the end of 2015. This included both the creation of BIM objects, the datasets that go along with them and the hosting of these for public and professional use.

Having researched a number of options it became clear that NBS were leading the field with their NBS BIM Object Standard and appeared to be the most closely aligned with what the Government was trying to achieve. This was an easy decision for me as I had already worked with RIBA Insight/NBS for the inclusion of our products in RIBA Product Selector, NBS Plus and NBS Create. This may have been why the BIM project was delegated to me too!

I liked the way NBS products worked together not only for us as a manufacturer, but more importantly for the end user. This included the plugins for software platforms so that specifiers and designers didn't have to exit



Ecoprod went live with 30 BIM objects in December 2015 including Miscea LIGHT 2 in 1 touch-free sensor tap with integral soap dispenser

their design software to find and include our products. Also, they weren't just selling me a product for the sake of a sale, as they were somewhat impartial in their following of the Government's objective and their BIM standard is widely being adopted globally. The development of the free-to-use NBS National BIM Library and the BETA and then final release version of the NBS BIM Toolkit that came along during 2015 showed that they were committed to a movement and change that was bigger than NBS themselves.

The other deciding factor was that, because NBS were setting the standard, they also knew how products should be represented to meet that standard. I didn't have time to oversee the creation of objects and datasets that met what architects and specifiers were expecting to find. I also wasn't prepared to entrust someone with creating those objects and datasets if they didn't know how they should be presented for all to use.

NBS carried out the bulk of the work including the 2D and 3D representation of the products as objects, but I did need to check and fill in missing data. Because BIM includes data that will go through to the Facilities Management company that manages a building after the initial build project, I was also concerned to include enough data to make their job easier. It could be that O&M manuals become a thing of the past with data so I wanted to make sure that every necessary detail was included. This is why I am so enthusiastic about BIM. Unlike CAD it is more than just the initial build project. The ongoing life cycle of any product is better managed and the Facilities Management role has got to be far easier!

Ecoprod went live with 30 products in the NBS National BIM Library on 2nd December 2015. "Initial mission accomplished but the BIM movement doesn't stop - get on board!"

Although there was, is and continues to be much discussion around BIM, we quickly realised that we needed to take this change seriously, as it was being driven by a clear mandate from the UK Government in relation to public sector projects from 2016.



Lee Jones
BIM Manager,
Ideal Standard



BIM Technology makes specification simple for Ideal Standard



Since May 2015, leading UK provider of innovative and design-driven bathroom solutions, Ideal Standard International, has partnered with NBS to host its Building Information Modelling (BIM) objects on the NBS National BIM Library.

This means that Ideal Standard, Armitage Shanks and Sottini brands all have a complete portfolio of BIM products available for commercial and residential housebuilder projects. From April 2016 all government-funded construction projects need to incorporate BIM in their plans.

With its long history and extensive experience, the company is keen to invest in advanced technology to help improve the building and planning process.

Ideal Standard has committed to hosting 3,000 products within the library, which is the primary source of BIM content in the UK. Before submitting its initial objects for cataloguing, Ideal Standard conducted extensive research into the key points needed in order to successfully create BIM objects. It found that structured data and geometry in the simplest form possible were the main priorities, along with keeping file sizes small.

Products are rarely manufactured based on BIM models, so there is no need for them to be as detailed as production models, in most instances. The object is used only for the client to aid specification, layout planning and operation through the data it holds. Ideal Standard has used Revit and Inventor as its software options for geometric perfection.



All manufacturers, of course, already have extensive data. The challenge is structuring this in a way which is BIM-compliant, as different amounts of information are needed at each stage of a project. Ideal Standard uses COBie to cover the main brand and product-specific data, while IFC is used to outline the most basic data. NBS Create, which will eventually supersede the current building specification system, is incorporated for specification purposes.

Since Ideal Standard first worked with BIM, the process of structuring data and geometry has been improved immeasurably by the support offered by NBS, including the provision of free downloads and criteria, such as the NBS BIM Object Standard, which outlines every requirement needed to achieve Level 2 BIM compliance.

The process of submitting the finished object is also ultra-simple: Ideal Standard simply submits the object which is checked against relevant criteria by the NBS and awarded a pass or fail. Clear feedback is also provided so that corrections can be easily and efficiently made.

Ideal Standard has found that working with BIM has provided a high reward for a relatively small investment; an ideal scenario for any business when working with planning and specification.

All manufacturers, of course, already have extensive data. The challenge is structuring this in a way which is BIM-compliant.

The impact of BIM on product selection throughout the project timeline



David Bain
Research Manager,
NBS

Who chooses products? When and how do they do it?

On the face of it, you might think that the answers to these questions are simple – designers select the products they want for a building when they write the specification, often at the eleventh hour, just before the project goes out to tender. Whilst this is a common description of product selection, it is certainly not the only way that designers specify products. What's more, as BIM transforms the design process, the process of product selection is transforming too.

On traditionally procured projects, the architect makes many of the product decisions as they complete their specification – typically at the Design Stage of the digital Plan of Work (Stage 4). Research that we carried out last year shows that traditional procurement is not the only method widely used by architects: 37% of design consultants most commonly work on design and build projects. In these cases, contractors and subcontractors will be making many of the product decisions. And, of course, consultants other than architects specify products too – M&E engineers, civil and structural engineers, landscape architects, architectural technologists and lighting designers, to name but a few.

BIM and the Plan of Work promote the evolution of project information, including product selection, as design intent emerges and is realised. The design, the model and the specification are started early, and the levels of detail added throughout the Plan of Work timeline, through collaboration within and beyond the project team. Some product decisions are made as the design concept evolves and the outline specification is written – much earlier than Stage 4. We also know that some decisions aren't made until construction has started (Stage 5): choices of finish and door furniture, for example, can sometimes be left until after the building fabric is in place and there is more certainty about the remaining budget.

It's not just during design and construction that people choose products. When the building is in use, products need replacing as they reach the end of their life. Here, BIM can make it much easier for facilities managers to know which products they have in their building, and to find the models and manufacturers when it is time to replace them.

Looking at the Plan of Work, this means that there are many people who make product decisions. Architects, architectural technologists, engineers, surveyors and contractors will choose products; but specialist designers, subcontractors, facilities managers and clients also do so. These decisions could be made at Plan of Work Stages 2, 3, 4, 5 or 7. In some cases, products may be considered as early on as Stage 1 if the client knows that they require a particular product to meet the brief – perhaps a particular colour of cladding to match their branding.

Therefore designers, clients, contractors and facilities managers all make decisions about products throughout the project timeline. What is different at each stage is the information that is required and the format that it is in. Product selection isn't just about BIM, of course: specifications are, and will remain, the most important documents for recording product selection and product attributes. But BIM is helping professionals make product decisions, visualise these in their overall model, and ensure that they have the technical data they need.

Using our understanding of the market and the research we carry out with architects, engineers, contractors and others, we have mapped the product lifecycle stages, and the resources specifiers use to help them make product decisions, to the Plan of Work. In the sections overleaf, we talk about what happens in terms of product selection at each stage.

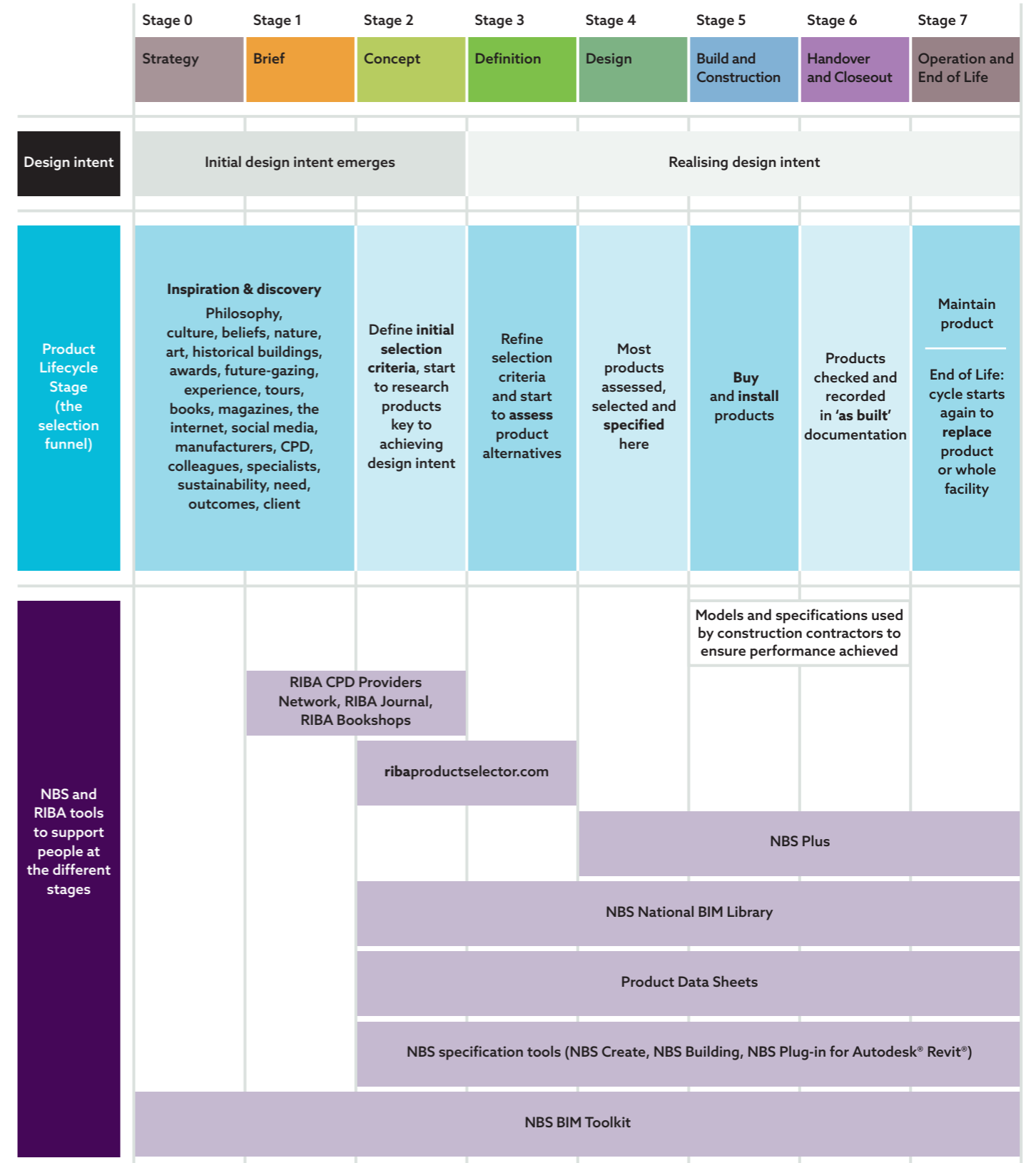



Inspiration and discovery

The product lifecycle is circular in that products are researched, selected, specified, purchased, installed, used, recycled and then researched and selected again. It can also be seen as a funnel. At the early stages (the wide end of the funnel), the people making decisions draw on a wide range of information sources. Some of these are conscious and planned – an engineer learning about new product innovations in a CPD session, for instance. Others might be conscious but experienced by chance: an architect may pass by or read about a new building and be inspired by it (or a specific detail of it). But some could be unconscious and shaped more by beliefs (a passion for zero carbon design, perhaps) or an interest in certain aesthetic movements, or historical periods.

At Stages 0 to 1, there is unlikely to be much formal research into products. Instead, clients and lead designers will be drawing on their experience, which encompasses these diverse sources of inspiration and discovery. They may have saved some of their discoveries: by bookmarking a webpage or social media site or book, saving a manufacturers' CPD presentation, or keeping hold of a brochure.

Designers, clients, contractors and facilities managers all make decisions about products throughout the project timeline.

Defining selection criteria

The core design team has been assembled: commonly the architect, structural engineer and services engineers. They will each start thinking about those products central to achieving design intent. Here they might start to define the selection criteria for these products: the building may be in a conservation area where only timber-framed windows are permitted, for example, or the client may wish to achieve a particular BREEAM certification and the services engineer may have particular sources of renewable energy generation in mind.

These designers are initially likely to draw on their experience of using particular products in the past or those sources of inspiration described above. But they may need to start some cursory research – searching to check that a product has not been superseded, or that its performance characteristics haven't changed. This might involve digging out those CPD presentations, books or magazines they have kept, or they may turn to internet search engines and directories to find basic product details. Therefore, at this stage, it's important for specifiers to be able to quickly lay their hands on product information they've saved, or that they can easily find basic product details like manufacturer and product name.

Assessing product alternatives

At Stage 3, the core design team will be preparing specifications and drawings for planning applications, so they may have produced outline specifications and included some product details. There might be a model, perhaps containing some manufacturers' BIM objects. They may be downloading product data sheets, specifications and BIM objects from manufacturer websites and technical libraries. They may also involve other designers and consultants, such as landscape architects and fire safety consultants, who bring their own ideas about products.

At this stage, specifiers want to be able to identify the performance data quickly so they can compare alternatives and make the best decision. They might want phone numbers and emails so they can start a dialogue with suppliers.

After planning consent has been granted, the project team continues to evolve (on a traditional project), or a main contractor will be appointed for a design and build project – and they in turn will appoint their own design team.

BIM and tools like NBS Create are helping designers to build their specifications as the design takes shape, but this change in working habits takes time to become embedded.

Specification

While specification may have begun at the concept or design stages, we know that much still happens at the design stage. BIM and tools like NBS Create are helping designers to build their specifications as the design takes shape, but this change in working habits takes time to become embedded. At this stage, in particular, time is in short supply and designers want technical information in a simple format that they can easily assess and put into their specifications and models. As well as performance data and certification information, they may also want to base decisions on things like availability and locality of supply, or availability of competent installers – so it can be useful if suppliers provide this information.

Where they are confident in their knowledge of products, specifiers want to be able to easily copy and paste product specification details, or to download a BIM object – 71% of respondents to this year's BIM Survey want manufacturers' BIM objects. For those that they know less about, or for more bespoke products or systems, they value guidance from manufacturers. They often want to speak to a technical expert who can help them choose the right product or help them complete their specification accurately and quickly. Once they've done this, using NBS Plus within NBS Create, they can integrate this with the model.



Purchase, installation and handover

Specialist subcontractors and installers will purchase and install products as part of Stage 5: build and construction. They'll want clear and detailed drawings and specifications to follow to ensure that they are installing exactly the right product in the correct manner. Complete and accurate specifications help here. If manufacturers have provided the specification or BIM object, designers and contractors will know that they are all working to the latest information. Specialist subcontractors have also told us that design which takes adjacent products and buildability into account aids construction on-site. If guidance about buildability is provided at the design stages, this can help make sure that the most suitable product is chosen, and prevents hold-ups and changes down the line.

As construction takes place, contractors will update and supply the 'as-built' information, which may include the model, drawings, specifications, operation and maintenance manuals and warranties. With BIM, there is an opportunity to ensure that a fully updated 3D model of the building is handed over to the user.

Maintenance, end of life and replacement

The completeness and quality of 'as-built' information can vary, but there is a sense that it is improving. Project teams working to Level 2 BIM will increasingly need to make sure that a complete and updated set of documentation is provided to those operating a building. This means that facilities managers can maintain installed products effectively, and therefore maintain building performance. If BIM has been adopted on the project, facilities managers will have the tools to know exactly what they have in their buildings, and can easily contact the manufacturer to purchase replacements.

Find out more

In this article, I have painted a very broad picture of the product lifecycle and the digital Plan of Work. I have highlighted how BIM is now embedded in the product lifecycle at different stages. This will only increase as more organisations and professionals adopt BIM. Early adopters of BIM, particularly designers, need BIM objects for the range of products and systems that they want to use. Increasingly, those who do not provide information about their products in a BIM-ready format will not have their products selected as the number of BIM projects increases.

Our industry is complex, however. The people involved, the decision-making criteria and the information that people need when specifying varies depending on sector, procurement route, project, product type and the people making the decision.

This is where we can help. We carry out research tailored to individual manufacturers and their product range. Using our industry knowledge and access to the range of professionals across the Plan of Work, we know who to contact, how and what to ask. We also know how to interpret what they say in the context of wider developments in the industry and what that means for you, your marketing and product development. If you would like to find out about what a particular group of specifiers think about your product or brand, or the latest innovations they are seeing, please call us for an informal conversation on [0191 244 5725](tel:01912445725) - we'd be glad to help.

You can also download our brochure at riba-insight.com/solutions/marketresearch.asp

Strategic market research for manufacturers

NBS Research provides strategic, bespoke research for construction manufacturers and suppliers.

- Better understand how your products are chosen by designers and contractors.
- Review your branding and positioning.
- Refine your communications so that your messages reach the right audience.

All research is carried out by the NBS Research Team, which has an unrivalled knowledge of design, specification and product selection. We have a proven track record within the construction industry and have produced a wide range of specialist reports including the NBS National BIM Report.

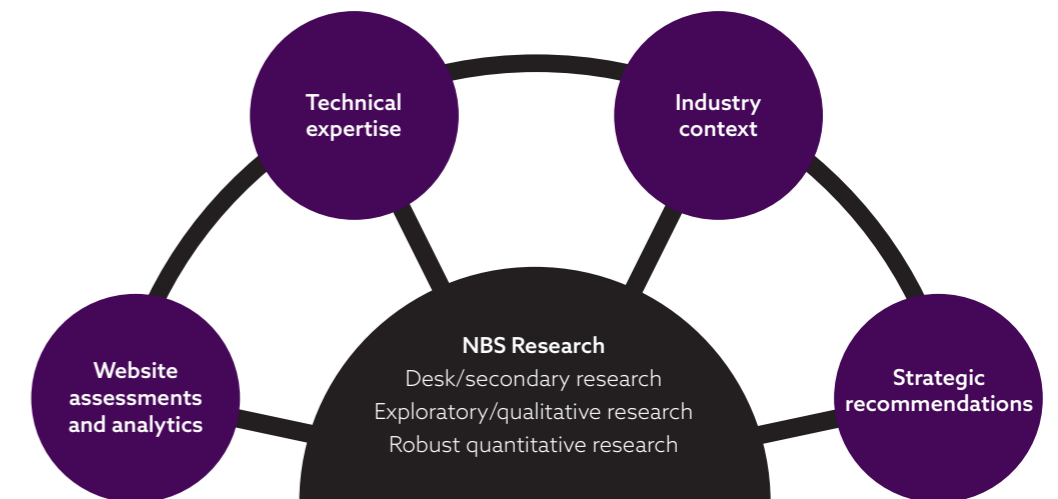

For an informal, no obligation conversation, contact David Bain, Research Manager:

0191 244 5725

david.bain@ribaenterprises.com

riba-insight.com/solutions/marketresearch.asp

NBS and RIBA Insight - Connecting the construction industry with our unique combination of specification, building product and construction knowledge expertise.



NBS and RIBA Insight
Connecting the construction industry

The Old Post Office
St Nicholas Street
Newcastle upon Tyne
NE1 1RH

Follow us on Twitter

@RIBAInsight

@theNBS

For manufacturer enquiries

T **0345 200 1056**

E **info@riba-insight.com**

W **nationalBIMlibrary.com**

